

NOTES:

1. THIS PLAT IS FOR THE SOLE PURPOSE OF SHOWING AN EASEMENT, NO BOUNDARY SURVEY WAS PERFORMED.
2. THE EASEMENT SHOWN HEREON REPRESENTS A PORTION OF THE INTEREST IN PROPERTY DESCRIBED IN DB 883 PG 630 , AND KNOWN AS PARCEL NUMBER 98-A-1.
3. BEARINGS, DISTANCES, AND MONUMENTS SHOWN HEREON MAY OR MAY NOT CONFORM WITH THOSE THAT WOULD BE SHOWN ON AN ACTUAL BOUNDARY SURVEY, AND NO CERTIFICATION IS MADE TO THAT EFFECT.
4. THIS PLAT HAS BEEN PREPARED WITHOUT THE BENEFIT OF A TITLE REPORT AND DOES NOT NECESSARILY INDICATE ALL ENCUMBRANCES UPON THE TITLE.

EASEMENT AREAS:

30' PERMANENT UTILITY EASEMENT: 59,107 SF
 VARIABLE WIDTH TEMPORARY CONSTRUCTION EASEMENT: 43,066 SF

LEGEND

- PROPERTY LINE
- SS —— SANITARY SEWER LINE
- - - SS - - - EXISTING SANITARY SEWER LINE
- ▒ PERMANENT UTILITY EASEMENT
- ▨ TEMPORARY CONSTRUCTION EASEMENT
- ⊙ EXISTING MANHOLE
- ⊙ SANITARY MANHOLE
- ⊙ POST FENCE POST
- POINT

LINE TABLE		
LINE	LENGTH	BEARING
L1	10.00	N61°14'03"E
L2	30.01	N61°14'03"E
L3	10.00	N61°14'03"E
L4	27.47	S29°50'52"E
L5	83.25	S23°35'59"E
L6	70.34	S12°08'56"E
L7	137.75	S13°24'01"W
L8	198.07	S82°42'16"E
L9	50.00	S7°17'44"W
L10	220.01	N82°42'16"W
L11	205.41	S70°50'06"W
L12	195.21	S72°21'39"W
L13	353.94	N84°45'41"W
L14	72.89	S18°43'17"W
L15	313.65	S16°54'51"W
L16	41.11	N73°05'25"W
L17	102.28	S50°37'23"W
L18	15.00	S39°22'37"E

LINE TABLE		
LINE	LENGTH	BEARING
L19	178.89	S50°37'23"W
L20	38.31	N9°53'20"E
L21	45.97	N9°53'20"E
L22	38.31	N9°53'20"E
L23	86.00	N50°37'23"E
L24	15.00	S39°22'37"E
L25	161.21	N50°37'23"E
L26	237.67	N16°54'51"E
L27	113.11	N18°43'17"E
L28	383.25	S84°45'41"E
L29	184.43	N72°21'39"E
L30	196.92	N70°50'06"E
L31	140.53	N13°24'01"E
L32	53.99	N12°08'56"W
L33	75.51	N23°35'59"W
L34	25.68	N29°50'52"W
L35	49.46	S61°14'03"W

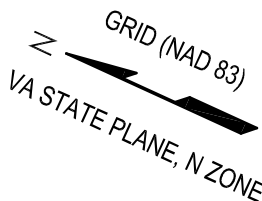
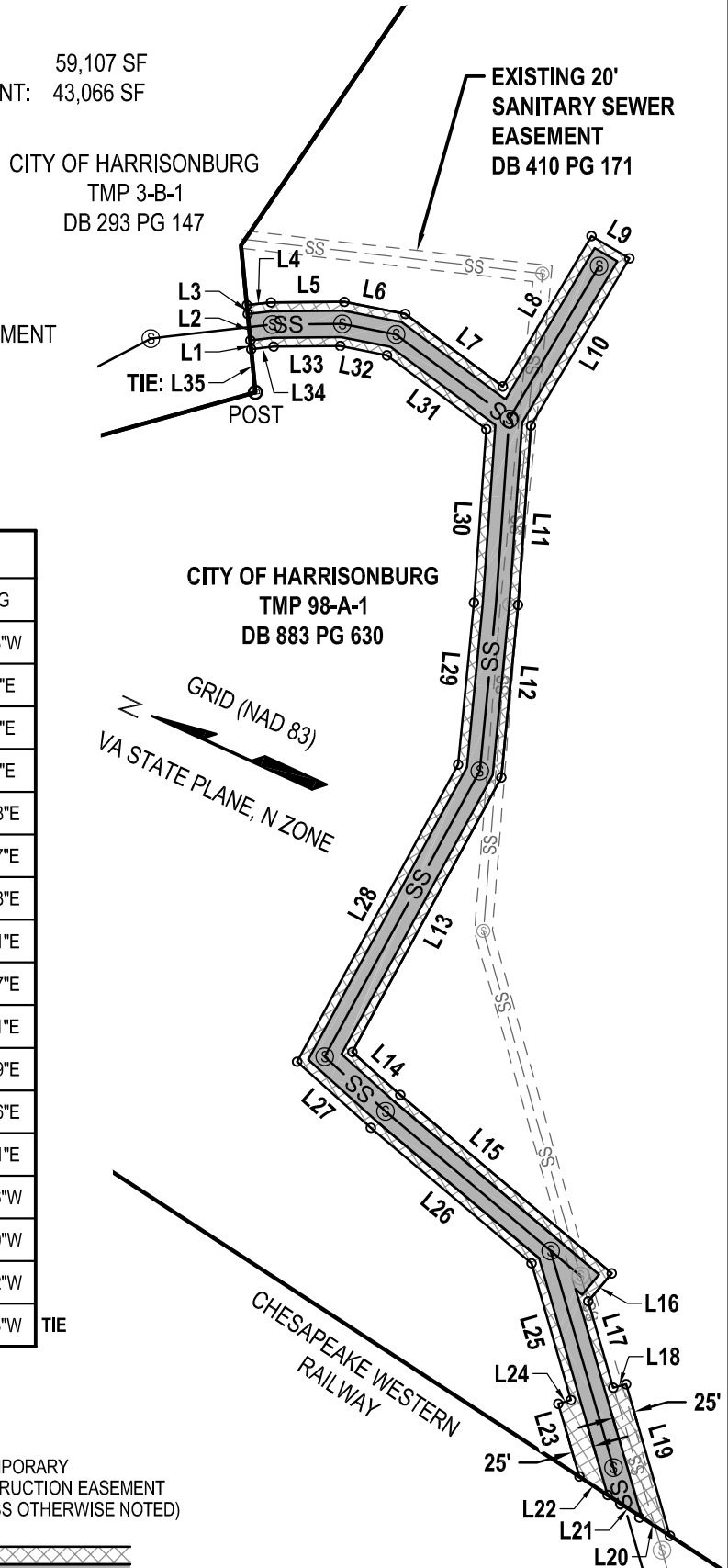

IF THIS DRAWING IS REDUCED, GRAPHIC SCALE MUST BE USED.

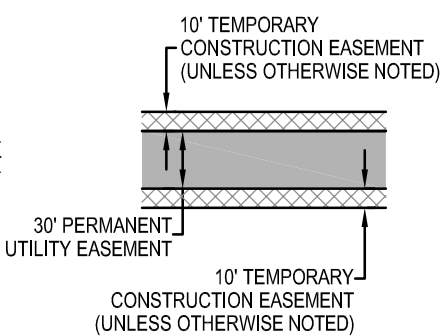
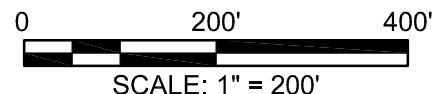

127 Nationwide Drive
 Lynchburg, Virginia 24502-4272

**HRRSA
 BLACKS RUN INTERCEPTOR**

PLAT SHOWING:
 TEMPORARY CONSTRUCTION EASEMENT AND PERMANENT UTILITY EASEMENT
 ACROSS TMP 98-A-1
 HARRISONBURG, VA

COMM NO: 222138	DRAWN: BSH	CHECK: WRM	DATE: 01/11/23	FILE: ES-03
--------------------	---------------	---------------	-------------------	----------------