

Date Application Received: 10/11/16

Total Paid: \$465.00 ~~xx~~ THD

Application for Change of Zoning District City of Harrisonburg, Virginia

Application Fee: \$375.00 plus \$30.00 per acre

Section 1: Property Owner's Information

Name: Tidewater Communications, LLC
Street Address: 1820 Heritage Center Way Email: _____
City/State/Zip: Harrisonburg, VA 22801
Telephone (work): 540-434-0331 (home or cellular): _____ (fax): 540-434-7087

Section 2: Owner's Representative Information

Name: David C. Nahm
Street Address: 92 N. Liberty Street Email: dcnahm@clark-bradshaw.com
City/State/Zip: Harrisonburg, VA 22802
Telephone (work): 540-433-2601 (home or cellular): _____ (fax): 540-433-5528

Section 3: Description of Property

Location (street address): 1820 Heritage Center Way
Tax Map Number: Sheet: 122 Block: B Lot: 2 Total Land Area (acres or square feet): 2.14
Existing Zoning District: B-2C Proposed Zoning District * : Amend Proffers
Existing Comprehensive Plan Designation: Low Density Mixed Residential

**If applying for conditional rezoning, provide a letter stating proffers on separate sheet of paper*

Section 4: Names and Addresses of Adjacent Property Owners (Use separate sheet for additional names)

North: see attached
East: see attached
South: see attached
West: see attached

Section 5: Certification

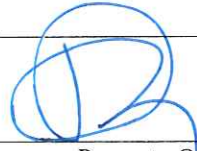
I certify that the information contained herein is true and accurate. Signature:  _____
Property Owner

PLEASE NOTE – If a Traffic Impact Analysis is required, this application shall not be considered accepted until the TIA has been reviewed and TIA fees paid. More information at www.harrisonburgva.gov/site-development

ITEMS REQUIRED FOR SUBMISSION

- Completed Application
- Survey of Property
- Description of Proposed Use
- Adjacent Property Owners
- TIA Determination Form OR Accepted TIA Letter, signed by Public Works

- Fees Paid
- Source Deed
- Proffers (if applicable)
- _____

M. STEVEN WEAVER
MARK B. CALLAHAN
TODD C. RHEA
MATTHEW C. SUNDERLIN
BRADLEY J. MOYERS
DAVID C. NAHM
QUINTON B. CALLAHAN

CLARK & BRADSHAW, P. C.
ATTORNEYS AT LAW
92 NORTH LIBERTY STREET
P. O. BOX 71
HARRISONBURG, VIRGINIA 22803-0071
TELEPHONE (540) 433-2601
FACSIMILE (540) 433-5528
WWW.CLARK-BRADSHAW.COM

HENRY C. CLARK
1924-2013
V. STEPHEN BRADSHAW
RETIRED
ELLEN H. BRODERSEN, C.P.A.
AMY L. RUSH, C.P.A.
(NOT ATTORNEYS)

October 6, 2016

Ms. Debra Fitzgerald, Chair
City of Harrisonburg Planning Commission
City Hall
409 South Main Street
Harrisonburg, VA 22801

RE: Proposed STL tower on Heritage Center Way

Dear Ms. Fitzgerald:

I represent Tidewater Communications, LLC, and Harrisonburg Radio Group (collectively "HRG") with regard to the Application for Change of Zoning District. Concurrent with this Application, my client has also filed an Application for a Special Use Permit. My client seeks to replace the forty foot (40') radio tower currently in use on its property with a one hundred and twenty foot (120') tower for the following reasons.

HRG is a local radio broadcast company which broadcasts a seven FM and AM channels throughout the area, including WSVA 92.1fm/550am (new/talk), WMQR 96.1fm (adult contemporary), WSIG 96.9 (country), WQPO 101fm (contemporary hits) and WHBG 101.3fm/1360am (sports radio).

Due to the low elevation of the radio station in relation to the surrounding landscape, since its construction in 2009, HRG has suffered from low signal levels. HRG is currently using a 40' self-supporting tower to send out audio signals across the adjacent field to the old WSVA studio location which was originally built in the 1950's.

The current tower is barley tall enough for the station signals to cross the hill crest, causing signals to be unreliable during storms. Additionally, the signal drops when the grass is cut in the adjacent pasture due to the metal of mower. Metal is a reflective surface that interferes with radio waves and since the signal is already weak, when the tractor drives in front of the signal path, HRG loses audio on all 7 stations simultaneously. The taller 120' self-supporting tower would resolve these issues by raising the signal height.

In addition to issues with transmitting the signal, HRG also has problems with reception. WQPO is the primary local station ("LP1") for receiving emergency broadcasts for this area. Being the LP1 station for the emergency broadcast system, HRG must monitor WWV, a radio station out of Charlottesville, Virginia. Due to height restrictions, that signal is very weak. This

affects the quality of the emergency alerts being sent out, including Amber alerts, flash flood alerts, tornado watches and warnings and periodic tests of the National Emergency Alert System.

As above, raising the height of the tower would resolve the reception issues encountered and would provide for the more reliable reception and transmission of emergency information and notices.

The 120' tower will not have any advertisements on it, nor will it be used for cellular phone transmitters. This tower will be specifically dedicated the purpose of supporting HRG's radio station signals and HRG's ongoing mission to serve this city and the surrounding counties. Whether it's a storm system moving into the area or another blizzard like in 2015, HRG wishes to provide this area with reliable radio signals. HRG wants to ensure that they continue to go above and beyond when it comes to the safety of the community. They feel the increase in the tower height will allow them to better serve the surrounding community.

The property was rezoned in 2007 to B-2C and at that time the owned made certain proffers. The proffers state that "[t]he basic layout as shown on the Proposed Rezoning Plan...is proffered." On the layout proffered, the 40' radio tower is shown. Because the new tower will be in a slightly different location, as shown on the drawings submitted herewith, we respectfully request that the proffers be amended to reflect the current tower location.

Thank you for your attention to this matter. I look forward to answering any questions the Planning Commission may have.

Regards,

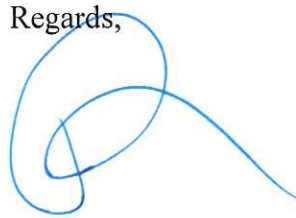
A handwritten signature in blue ink, consisting of several loops and a long tail extending to the right.

David C. Nahm

DCN/lcs

M. STEVEN WEAVER
MARK B. CALLAHAN
TODD C. RHEA
MATTHEW C. SUNDERLIN
BRADLEY J. MOYERS
DAVID C. NAHM
QUINTON B. CALLAHAN

CLARK & BRADSHAW, P. C.
ATTORNEYS AT LAW
92 NORTH LIBERTY STREET
P. O. BOX 71
HARRISONBURG, VIRGINIA 22803-0071
TELEPHONE (540) 433-2601
FACSIMILE (540) 433-5528
WWW.CLARK-BRADSHAW.COM

HENRY C. CLARK
1924-2013
V. STEPHEN BRADSHAW
RETIRED
ELLEN H. BRODERSEN, C.P.A.
AMY L. RUSH, C.P.A.
(NOT ATTORNEYS)

October 7, 2016

Allison Banks
City of Harrisonburg
406 South Main Street
Harrisonburg, VA 22801

RE: Rezoning of TM Parcel 122-B-2

Dear Ms. Banks:

This letter is submitted with the Application for Zoning Amendment for the property currently zoned B-2C, designated TM# 122-B-2

It is proffered that the estimated 2.14 acre portion of the property zoned as B-2C will be used only for the following uses permitted by right under section 10-3-90:

- 8) Radio and television stations and studios or recording studios.
- 18) Public uses.

It is also proffered that:

1. The proffers dated February 5, 2007 are still in effect ("2007 Proffers").
2. Proffer number 1 of the 2007 Proffers will be hereby amended for the relocation of the STL radio tower as shown on the attached drawing.

Thank you for your attention to this matter.

Regards,

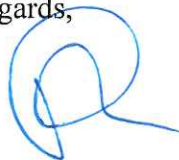

David C. Nahm

DCN/lcs

2007 Proffers

February 5, 2007

Adam Fletcher
City of Harrisonburg
409 South Main Street
Harrisonburg, VA 22801

RE: Rezoning of TM Parcel 122-B-2

BE: 1725

Dear Mr. Markel:

This letter is submitted with the Application for Zoning Amendment for the property currently zoned R-1, designated TM# 122-B-2.

It is proffered that the 2.14± acre portion of the property rezoned as B-2C will be used only for the following uses permitted by right under section 10-3-90:

- 8) Radio and television stations and studios or recording studios.
- 18) Public uses.

It is also proffered that:

1. The basic layout as shown on the Proposed Rezoning Plan, hereto attached, is proffered.
2. Access to the site will be along a proposed driveway commencing at the existing CG-11 entrance on Garbers Church Road onto the Myers' Property (T.M. #117-B-1). The driveway will connect to the proposed site across property owned by the Valley Brethren-Mennonite Heritage Center and join the Center's existing driveway. Negotiations with the Myers family and the Heritage Center are on-going. Both parties have given tacit approval to the concept and believe appropriate easements can be agreed to. Letters of agreement are included with this submission.
3. A landscape /tree screen and/or a six foot fence will be provided along portions of the adjoining neighbor's property line (T.M. 117-E-1) as specified by the current resident.
4. The proposed building will not exceed 35' in height and will be constructed generally of brick and drivit with an asphalt shingle roof.
5. No free standing signs greater than eight feet in height will be installed on the property.
6. Site lighting will be diverted downward and will meet City requirements.

Your time and consideration is appreciated.

Sincerely,



Susanne Myers
General Manager

City of Harrisonburg, VA

Determination of Need for a Traffic Impact Analysis (TIA)

Applicant Tidewater Communications, LLC
Name of Project _____
Project Address or TM # 122-B-2
Proposed Use in General Radio Tower

Breakdown of Peak Hour Trip Generation by Land Use per ITE:

Land Use 1.	Type & Code #	<u>General Office Building (730)</u>
	Unit base (SF, # units, # empl., etc.)	<u>SF</u>
	Quantity	<u>0 added</u>
	Peak Hour Trip Generation (use greater of AM or PM and indicate which one)	<u>0 - PM</u>

Land Use 2.	Type & Code #	_____
	Unit base (SF, # units, # empl., etc.)	_____
	Quantity	_____
	Peak Hour Trip Generation (use greater of AM or PM and indicate which one)	_____

Land Use 3,4, etc. (attach additional information as necessary)

Total Project Peak Hour Trip Generation 0 - PM

(reserved for City staff)

TIA Required? Yes _____ No X

Comments:

Accepted by: 
Signature

Date: 10-12-16

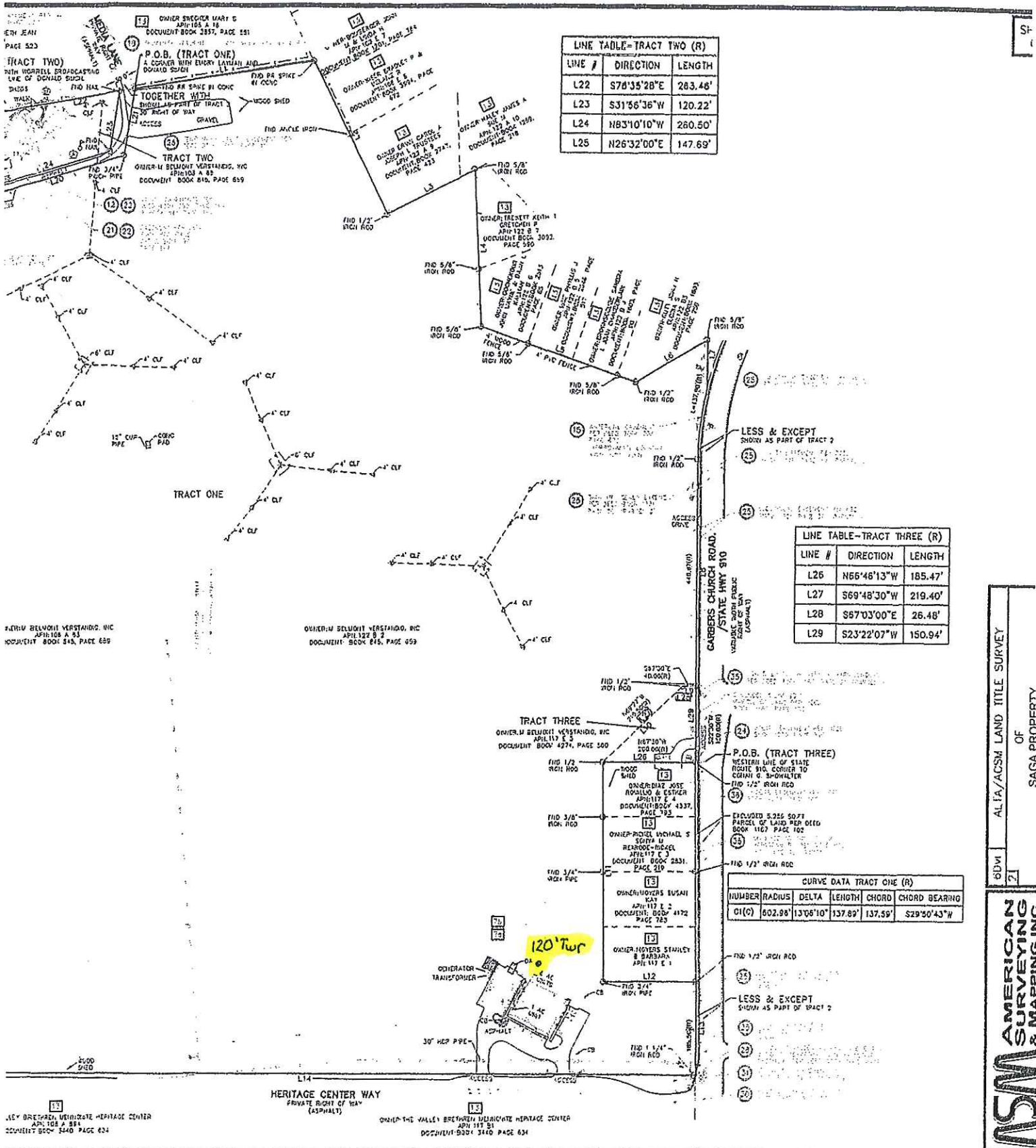

LINE TABLE-TRACT TWO (R)

LINE #	DIRECTION	LENGTH
L22	S78°35'28"E	283.48'
L23	S31°56'36"W	120.22'
L24	N83°10'10"W	260.50'
L25	N26°32'00"E	147.69'

LINE TABLE-TRACT THREE (R)

LINE #	DIRECTION	LENGTH
L26	N66°46'13"W	185.47'
L27	S69°48'30"W	219.40'
L28	S87°03'00"E	26.48'
L29	S23°22'07"W	150.94'

CURVE DATA TRACT ONE (R)

NUMBER	RADIUS	DELTA	LENGTH	CHORD	CHORD BEARING
01(C)	602.98'	13°06'10"	137.89'	137.55'	S29°50'43"W

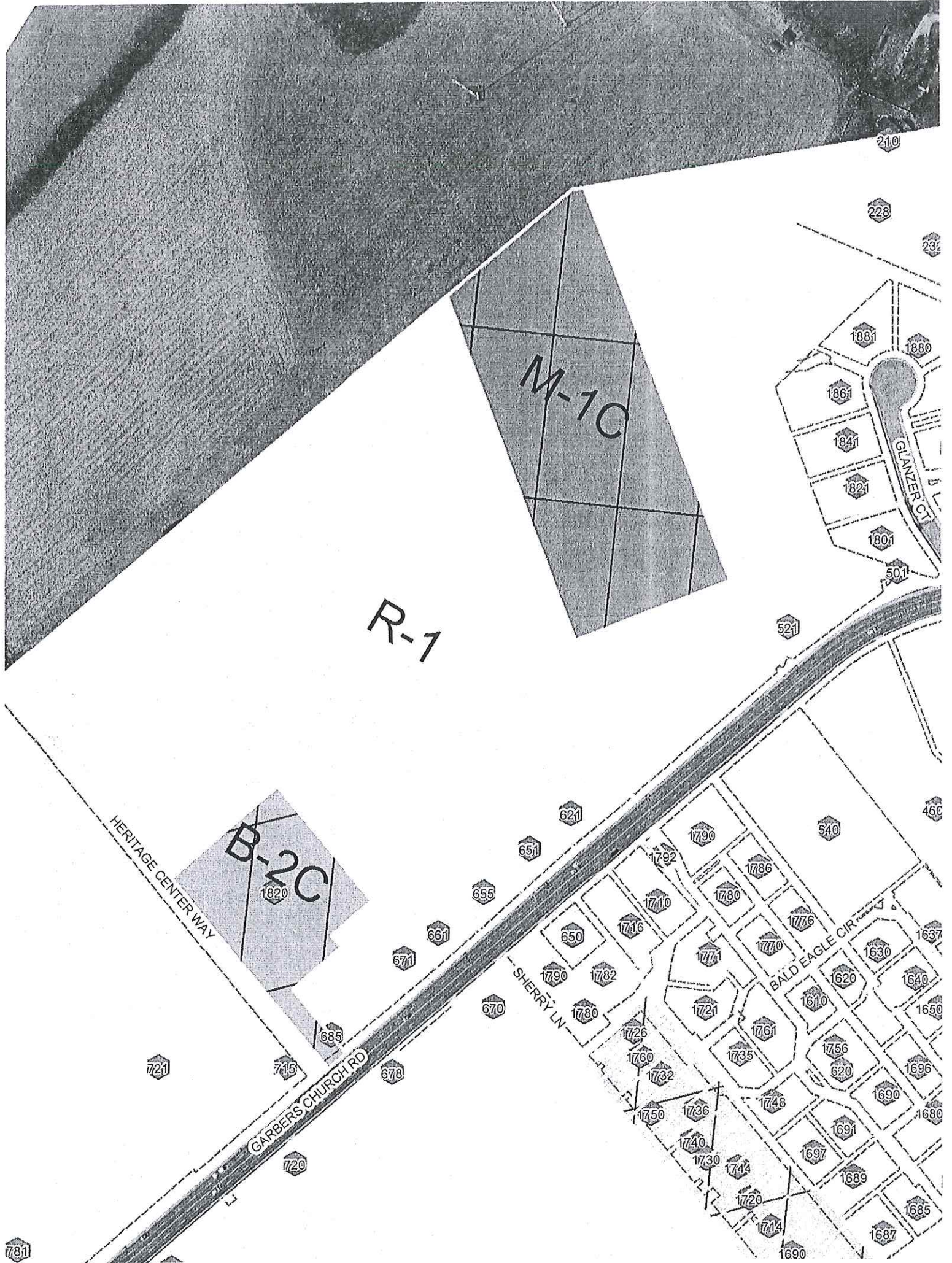

Tax Map	Owner	Address
117 B 1 (Harrisonburg) 108(A)89A1 (Rockingham)	The Valley Brethren Mennonite Heritage Center	P.O. Box 1563 Harrisonburg VA 22803
117 E 1 (Harrisonburg)	Karen Lee Moyers	671 Garbers Church Rd. Harrisonburg VA 22801
117 E 2 (Harrisonburg)	Susan Kay Moyers	671 Garbers Church Rd. Harrisonburg VA 22801
117 E 3 (Harrisonburg)	Michael S. Rickel & Sonya M. Rexrode-Ricklel	655 Garbers Church Rd. Harrisonburg VA 22801
117 E 4 (Harrisonburg)	Jose Romillio Diaz & Marcela Esther Espinoza Martinez	651 Garbers Church Rd. Harrisonburg VA 22801
117 E 5 (Harrisonburg)	Tidewater Communications, LLC	
117 D 2 (Harrisonburg) 117 F 4 (Harrisonburg)	City of Harrisonburg	345 S. Main St. Harrisonburg VA 22801
116 C 1 (Harrisonburg)	Heritage Estates	245 Newman Ave. Harrisonburg VA 22801
123 H 5 (Harrisonburg)	Khalif & Barbara Rashid	540 Garbers Church Rd. Harrisonburg VA 22801
123 H 4 (Harrisonburg)	Darrell L. & Emily K. Gelser	460 Garbers Church Rd. Harrisonburg VA 22801
123-H-1 (Harrisonburg)	Norman H. & Dorothy L. Kreider	470 Garbers Church Rd. Harrisonburg VA 22801
122 B 3 (Harrisonburg)	John H. & Gloria S. Rutt	1801 Glanzer Ct. Harrisonburg VA 22801
122 B 4 (Harrisonburg)	Sandra L. Brownscombe & Joan Chamberlain	1821 Glanzer Ct. Harrisonburg VA 22801
122 B 5 (Harrisonburg)	Phyllis J. Wine	1841 Glanzer Ct. Harrisonburg VA 22801
122 B 6 (Harrisonburg)	John Wayne Gochenour and Dawn L. Kalman	1861 Glanzer Ct. Harrisonburg VA 22801
122 B 7 (Harrisonburg)	Keith T. & Gretchen P. Trevvett	1881 Glanzer Ct. Harrisonburg VA 22801
122 A 10 (Harrisonburg)	James A. & Sue M. Haley	232 Rorrer Circle Harrisonburg VA 22801
122 A 9 (Harrisonburg)	Carol A. & Joseph L. Ervin, Trustees of The Carol A. Ervin Trust Agreement dated 2/22/90	228 Rorrer Circle Harrisonburg VA 22801
108E(1)8 (Rockingham) 122 A 8 (Harrisonburg)	Bradley P. & Melanie R. Kiser	210 Rorrer Circle Rockingham VA 22801
108(A)67 (Rockingham) 108(A)67A (Rockingham)	J. Robert, Jr. & Keri Sue Brunk	2509 Rawley Pike Rockingham VA 22801
108(A)13 (Rockingham)	Weavers Mennonite Church c/o Pastor/Trustees	2501 Rawley Pike Rockingham VA 22801
108(A)66 (Rockingham)	James E. & Lavonne E. Rusmisl	225 Media Ln Rockingham VA 22801
108(A)15 (Rockingham)	Rodney J. Burkholder	406 Sugar Maple Ln Harrisonburg VA 22801
108(A)16 (Rockingham)	Mary S. Swecker	2275 Rawley Pike Rockingham VA 22801
108E(1)7 (Rockingham)	John M. & Linda H. Bomberger	174 Rorrer Circle Rockingham VA 22801

Date Application Received: 9/12/16 THD Total Paid: \$ 465 THD

received
9/12/16

Application for Special Use Permit City of Harrisonburg, Virginia

Fee: \$375.00 plus \$30.00 per acre NOTE: If applying for a Wireless Telecommunications Facility allowed only by SUP, then also submit a wireless telecommunications facility application.

Property Owner's Name: Tidewater Communications, LLC

Street Address: 1820 Heritage Center Way Email: _____

City: Harrisonburg State: Virginia Zip: 22801

Telephone: Work 540-434-0331 Fax 540-434-7087 Mobile _____

Owner's Representative: David C. Nahm

Street Address: 92 N. Liberty Street Email: dcnahm@clark-bradshaw.com

City: Harrisonburg State: Virginia Zip: 22802

Telephone: Work 540-433-2601 Fax 540-433-5528 Mobile _____

Description of Property and Request

Location (Street Address): 1820 Heritage Center Way

Tax Map Number Sheet: 122 Block: B Lot: 2 Lot Area: 2.14

Existing Zoning Classification: B-2C

Special Use being requested: Replace existing radio tower with radio tower in excess of 75' (120') - Sec. 10-3-91 (12)

Please provide a detailed description of the proposed (use additional pages may be attached):
see attached

Names and Addresses of Adjacent Property Owners (Use separate sheet for additional names)

North: see attached

South: see attached

East: see attached

West: see attached

Certification: *I certify that the information contained herein is true and accurate.*

Signature: _____
Property Owner Representative

ITEMS REQUIRED FOR SUBMISSION

- Completed Application
- Site Plan
- Description of Proposed Use
- Adjacent Property Owners

Fees Paid

M. STEVEN WEAVER
MARK B. CALLAHAN
TODD C. RHEA
MATTHEW C. SUNDERLIN
BRADLEY J. MOYERS
DAVID C. NAHM
QUINTON B. CALLAHAN

CLARK & BRADSHAW, P. C.
ATTORNEYS AT LAW
92 NORTH LIBERTY STREET
P. O. BOX 71
HARRISONBURG, VIRGINIA 22803-0071
TELEPHONE (540) 433-2601
FACSIMILE (540) 433-5528
WWW.CLARK-BRADSHAW.COM

HENRY C. CLARK
1924-2013
V. STEPHEN BRADSHAW
RETIRED
ELLEN H. BRODERSEN, C.P.A.
AMY L. RUSH, C.P.A.
(NOT ATTORNEYS)

November 2, 2016

Ms. Alison Banks, Zoning Administrator/Senior Planner
City of Harrisonburg
City Hall
409 South Main Street
Harrisonburg, VA 22801

RE: Proposed STL tower on Heritage Center Way: Alternatives Considered

Dear Ms. Banks:

Thank you for taking the time to discuss my client's Applications for a Special Use Permit and Rezoning yesterday. We appreciated the chance to go over everything with you and Ms. Dang. One of the items that we discussed concerned the alternatives to the new STL tower that my client considered.

My client did consider other options to the new STL tower. As detailed in the letter attached to the Applications, due to the topography, the current tower encounters interruptions in its signal fairly regularly. The primary alternative that my client considered was running a fiber optic cable under the ground from the radio station on Heritage Way to the transmitter building on 130 Media Lane (which is located in Rockingham County).

Unfortunately there were several problems with this method. Between the Heritage Way and Media Lane buildings stand several radio towers, each of which has a series of metal wires radiating out 350', like the spokes of a wheel. There are also copper coaxial cables under the ground which have been there since the 1950s. Running the fiber optic cable across this land without running across the radio tower wires or the coaxial wires would be nearly impossible. Additionally, the distance would require a power booster box in the middle of the property which would be attractive to lightning and which, due to the proximity to the other underground wires and metal, could cause extensive damage to the radio towers and surrounding property.

One other option considered was transmitting the signal over the internet to the transmitter building. However, this would cause the radio signal to be lost anytime there was an interruption in internet service. In fact, while my client was working on drafting a letter for you, the internet went out at the radio station due to a break in the line.

Thank you again for your time. Please let me know if you have any other questions or concerns.

Regards,

A handwritten signature in blue ink, appearing to be 'DCN', written in a cursive style.

David C. Nahm

DCN/lcs

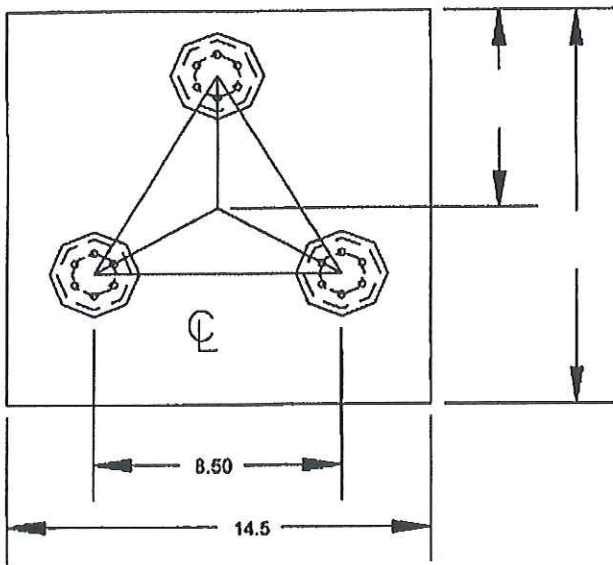

12.93CU. YDS.
CONCRETE REQUIRED

7.25

14.5

8.50

14.5

PRELIMINARY DESIGN NOT FOR CONSTRUCTION

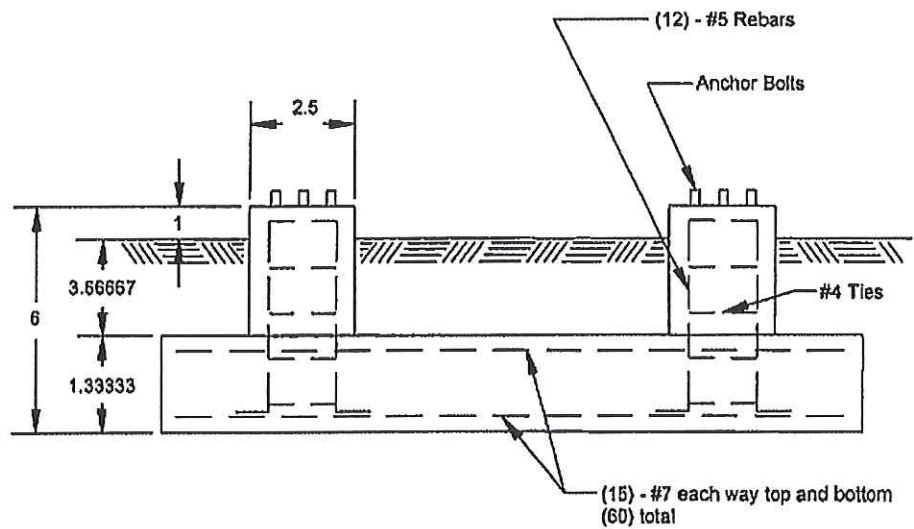

GENERAL NOTES

1. CONCRETE TO HAVE 4000 PSI MIN. COMPRESSIVE STRENGTH AFTER 28 DAYS.
2. REINFORCEMENT STEEL IS DEFORMED AND MEETS THE REQUIREMENTS OF ASTM A615 GRADE 60.
3. EMBEDDED STEEL TO HAVE 3" MIN. CONCRETE COVER.
4. DESIGN BASED ON NORMAL SOILS

TITLE: K1506-014 R1



**WORLD TOWER
COMPANY, INC.**

SCALE	DRN.	CKD.	DATE
FILE	DRAWING NO.		

Section	T6	T5	T4	T3	T2	T1
Legs	P3.5x2.26		P3x2.26		SR2	SR 1 1/2
Leg Grade						
Diagonals			A572-50			
Diagonal Grade						
Top Glits			A36			
Bottom Glits				L1 3/4x1 3/4x1/8		SR 7/8
Horizontals						SR 3/4
Sec. Horizontals						SR 3/4
Face Width (ft)	8.5			5.5		2.5
# Panels @ (ft)				16 @ 5		12 @ 3.20833
Weight (K)	5.0				0.5	0.1

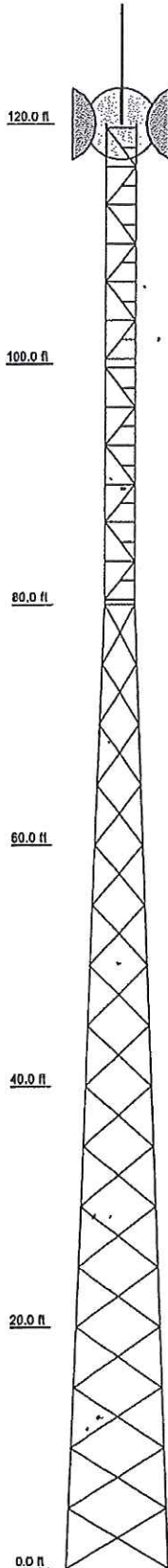

DESIGNED APPURTENANCE LOADING

TYPE	ELEVATION	TYPE	ELEVATION
Lightning Rod	120	6 FT DISH	120
6 FT DISH	120	6 FT DISH	120

MATERIAL STRENGTH

GRADE	Fy	Fu	GRADE	Fy	Fu
A572-50	50 ksi	65 ksi	A36	36 ksi	58 ksi

TOWER DESIGN NOTES

1. Tower is located in Rockingham County, Virginia.
2. Tower designed for Exposure C to the TIA-222-G Standard.
3. Tower designed for a 90.00 mph basic wind in accordance with the TIA-222-G Standard.
4. Tower is also designed for a 30.00 mph basic wind with 0.75 in ice. Ice is considered to increase in thickness with height.
5. Tower Structure Class II.
6. Topographic Category 1 with Crest Height of 0.00 ft
7. TOWER RATING: 95.4%

ALL REACTIONS
ARE FACTORED

MAX. CORNER REACTIONS AT BASE:

DOWN: 88 K
SHEAR: 6 K

UPLIFT: -77 K
SHEAR: 5 K

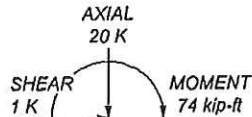

TORQUE 0 kip-ft
30.00 mph WIND - 0.75 in ICE

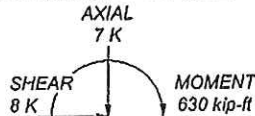

TORQUE 0 kip-ft
REACTIONS - 90.00 mph WIND

World Tower Company	Job: 120' WSSTP / K1506-014 R1		
1213 Compressor Drive	Project: Harrisonburg, VA		
Mayfield, Kentucky 42066	Client:	Drawn by: kirk	App'd:
Phone: (270) 247-3642	Code: TIA-222-G	Date: 06/12/15	Scale: N'
FAX: www.worldtower.com	Path:		Dwg No. E



Tax Map	Owner	Address
117 B 1 (Harrisonburg) 108(A)89A1 (Rockingham)	The Valley Brethren Mennonite Heritage Center	P.O. Box 1563 Harrisonburg VA 22803
117 E 1 (Harrisonburg)	Karen Lee Moyers	671 Garbers Church Rd. Harrisonburg VA 22801
117 E 2 (Harrisonburg)	Susan Kay Moyers	671 Garbers Church Rd. Harrisonburg VA 22801
117 E 3 (Harrisonburg)	Michael S. Rickel & Sonya M. Rexrode-Ricklel	655 Garbers Church Rd. Harrisonburg VA 22801
117 E 4 (Harrisonburg)	Jose Romillio Diaz & Marcela Esther Espinoza Martinez	651 Garbers Church Rd. Harrisonburg VA 22801
117 E 5 (Harrisonburg)	Tidewater Communications, LLC	
117 D 2 (Harrisonburg) 117 F 4 (Harrisonburg)	City of Harrisonburg	345 S. Main St. Harrisonburg VA 22801
116 C 1 (Harrisonburg)	Heritage Estates	245 Newman Ave. Harrisonburg VA 22801
123 H 5 (Harrisonburg)	Khalif & Barbara Rashid	540 Garbers Church Rd. Harrisonburg VA 22801
123 H 4 (Harrisonburg)	Darrell L. & Emily K. Gelser	460 Garbers Church Rd. Harrisonburg VA 22801
123-H-1 (Harrisonburg)	Norman H. & Dorothy L. Kreider	470 Garbers Church Rd. Harrisonburg VA 22801
122 B 3 (Harrisonburg)	John H. & Gloria S. Rutt	1801 Glanzer Ct. Harrisonburg VA 22801
122 B 4 (Harrisonburg)	Sandra L. Brownscombe & Joan Chamberlain	1821 Glanzer Ct. Harrisonburg VA 22801
122 B 5 (Harrisonburg)	Phyllis J. Wine	1841 Glanzer Ct. Harrisonburg VA 22801
122 B 6 (Harrisonburg)	John Wayne Gochenour and Dawn L. Kalman	1861 Glanzer Ct. Harrisonburg VA 22801
122 B 7 (Harrisonburg)	Keith T. & Gretchen P. Trevvett	1881 Glanzer Ct. Harrisonburg VA 22801
122 A 10 (Harrisonburg)	James A. & Sue M. Haley	232 Rorrer Circle Harrisonburg VA 22801
122 A 9 (Harrisonburg)	Carol A. & Joseph L. Ervin, Trustees of The Carol A. Ervin Trust Agreement dated 2/22/90	228 Rorrer Circle Harrisonburg VA 22801
108E(1)8 (Rockingham) 122 A 8 (Harrisonburg)	Bradley P. & Melanie R. Kiser	210 Rorrer Circle Rockingham VA 22801
108(A)67 (Rockingham) 108(A)67A (Rockingham)	J. Robert, Jr. & Keri Sue Brunk	2509 Rawley Pike Rockingham VA 22801
108(A)13 (Rockingham)	Weavers Mennonite Church c/o Pastor/Trustees	2501 Rawley Pike Rockingham VA 22801
108(A)66 (Rockingham)	James E. & Lavonne E. Rusmiser	225 Media Ln Rockingham VA 22801
108(A)15 (Rockingham)	Rodney J. Burkholder	406 Sugar Maple Ln Harrisonburg VA 22801
108(A)16 (Rockingham)	Mary S. Swecker	2275 Rawley Pike Rockingham VA 22801
108E(1)7 (Rockingham)	John M. & Linda H. Bomberger	174 Rorrer Circle Rockingham VA 22801